



## AS Direct Fired LPG Vaporizers

- For Propane, Butane, and LPG
- Capacities from 50 gph to 480 gph
- ASME, NFPA, FM
- Two-Stage  
Burner Regulator
- Manual Drain
- Powder Coated Cabinet
- Liquid Carryover  
Protection
- Automatic Ignition/Re-Ignition—9VDC
- Factory Tested



# What are LPG Vaporizers ?

LPG vaporizers are actually boilers. Instead of boiling water, they boil propane, butane, or another LPG (Liquefied Petroleum Gas). It may sound strange that heat is required to vaporize LPG when propane will boil at -44 °F and butane at 32 °F, but, when LPG vaporizes by expansion alone, it causes a refrigeration action. In applications with high LPG flow, the uncontrolled vaporization would freeze valves and burner nozzles. Therefore, controlled heat is required to offset the refrigeration action.

## How do Algas-SDI AS Direct Fired Vaporizers work ?

Liquid LPG supply is connected to the Liquid Inlet Valve. A stainless steel ball is resting on the actuator for the Liquid Inlet Valve, opening the valve, and allowing liquid LPG to enter the Vaporization Tube. The liquid level will rise until the stainless steel ball is lifted off the Liquid Inlet Valve Actuator by the buoyancy effect.

LPG gas from naturally occurring vaporization is led through the dual stage Burner Pressure Regulator and the Temperature Control Valve to the Burner on the bottom of the unit, where it is lit by the Burner Pilot. The hot gases from the Burner rise upward along the Vaporization Tube. Metal fins along the Vaporization Tube increase the heat transfer from the hot gases to the Vaporization Tube and the liquid LPG. The LPG vapor exits through the Vapor Outlet in the rear of the vaporizer.

Several components in the design of the vaporizers act as safety devices:

- If the demand on the vaporizer is higher than the vaporization capacity, the liquid level in the Vaporization Tube would rise. This would not only close the Liquid Inlet Valve, but also push the stainless steel bell against the section of the Vapor Outlet inside the Vaporization Tube, thereby closing off the outlet pipe and preventing the exit of liquid propane through the Vapor Outlet. Only a small amount of gas would be allowed to escape through a tiny gap in the seat of the ball against the Vapor Outlet line, thereby equalizing the pressure inside the Vaporization Tube and the pressure in the vapor output line. At the same time, the Temperature Control Valve will detect the cool liquid at its sensor and will open the gas flow to the burner. The increased heat stimulates the vaporization process and returns the unit to normal operation.
- If the pilot light should be extinguished, the integrated Burner Thermocouple Assembly would detect the drop in temperature and interrupt the gas supply to the burner.
- If an overpressure-situation occurs, the Pressure Relief Valve safely vents the systems to the atmosphere.

The Drain Valve located at the back of the vaporizer, and the "Drip Leg Valve" allow the easy removal of contaminations from the unit ("Heavy Ends").

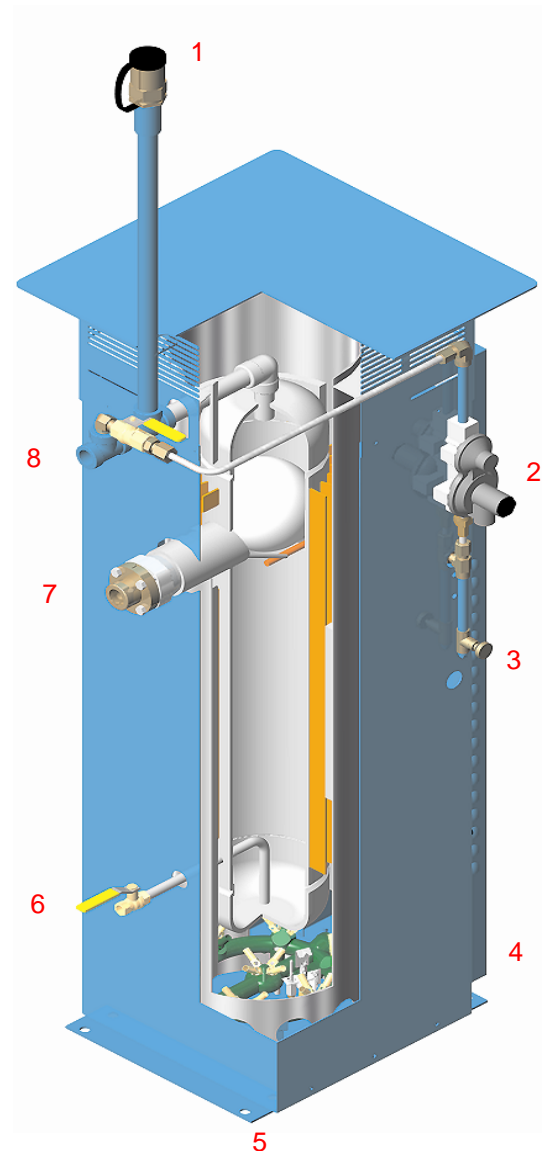

- 1 Pressure Relief Valve
- 2 Burner Pressure Regulator
- 3 Drip Leg Valve
- 4 Burner Jets
- 5 LPG Vapor Burner
- 6 Manual Drain Valve
- 7 Liquid Inlet Valve
- 8 Vapor Outlet

# Drawings, Specifications

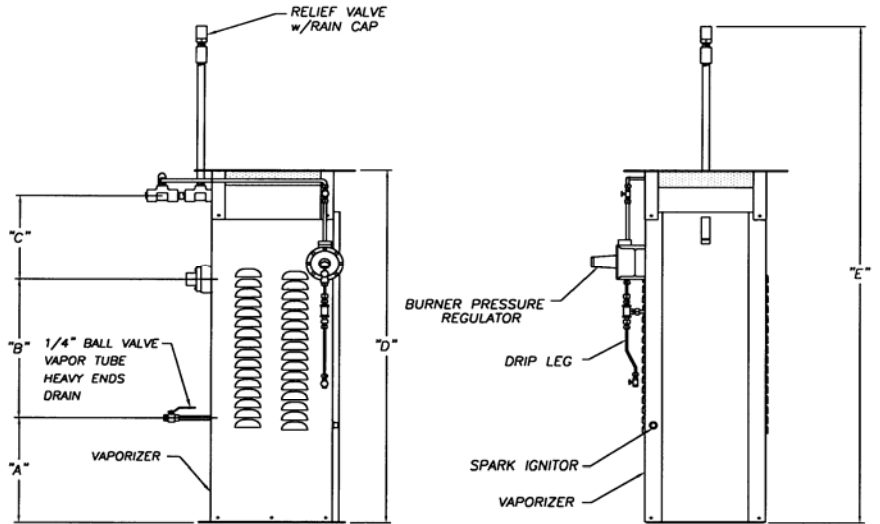

	AS-50	AS-80	AS-120
A	13" (330 mm)	13" (330 mm)	13" (330 mm)
B	14" (356 mm)	22" (559 mm)	31" (787 mm)
C	11" (276 mm)	11" (276 mm)	11" (276 mm)
D	41" (1041 mm)	49" (1245 mm)	58" (1473 mm)
E	59" (1499 mm)	67" (1702 mm)	76" (1930 mm)

SPECIFICATIONS		AS - 50	AS - 80	AS - 120
Type		Direct Fired Vaporizer with Dual Liquid Level Control and Dual Stage Burner Regulator.		
Vaporization Capacity	gph	50	80	120
Vaporization Capacity	kg/h	100	160	240
Design Temperature	°F (°C)	650 (345)		
Design Pressure	psi (bar)	250 (17)		
Test Pressure	psi (bar)	375 (25)		
Manufactured Construction		Vapor Tube conforms to ASME Boiler and Pressure Vessel Code, Section VIII Div 1. Conforms to latest edition of NFPA.		
Approvals		Approved for Factory Mutual (FM) or Industrial Risk Insurers (IRI) Installations.		
Standard Safety Features		Dual Liquid Level Control with Liquid Carryover Protection Pressure Relief Valve Protection (Vapor Tube) Pilot Thermocouple Manual Drain		
Burner Input	BTU/hr	70,000	100,000	140,000
Liquid Inlet Connection		3/4" FNPT		
Vapor Outlet Connection		3/4" FNPT		
Electrical Requirements		NONE		
Dimensions (D x W x H)	inch (mm)	17" x 14" x 59" (432 x 356 x 1499)	17" x 14" x 59" (432 x 356 x 1702)	17" x 14" x 59" (432 x 356 x 1930)
Dry Weight	lbs (kg)	180 (82)	200 (91)	250 (115)
Shipping Weight	lbs (kg)	210 (97)	230 (105))	280 (130)

Nominal Capacity for Propane/Butane @ 0°F Liquid Temperature. Dimensions and weights are approximate. Specifications subject to change without notice.

## Other AS Direct Fired Vaporizers from Algas-SDI.

**A**lgas-SDI manufactures AS Direct Fired Vaporizers in capacities of up to 480 gallons per hour. These units consist of a battery of 2, 3, or 4 AS-80 or AS-120 units in a common cabinet, with all interconnecting piping and controls installed at the factory. The units operate in parallel mode. Safety features and other functions are identical with those of the base units AS-80 and AS-120.

Model	Capacity	Heat Exchangers	Approx. Size (D x W x H)
AS - 160	160 gph (320 kg/h)	2 x AS - 80	24" x 22" x 58" (610 x 559 x 1473 mm)
AS - 240	240 gph (480 kg/h)	2 x AS - 120	24" x 22" x 76" (610 x 559 x 1930 mm)
AS - 360	360 gph (720 kg/h)	3 x AS - 120	35" x 22" x 76" (889 x 559 x 1930 mm)
AS - 480	480 gph (960 kg/h)	4 x AS - 120	45" x 22" x 76" (1143 x 559 x 1930 mm)



AS - 480

## **Our Address**

Algas-SDI International, LLC.  
1140 NW 46th ST  
Seattle, WA, 98107 USA

Phone           206-789-5410  
Fax              206-789-5414

E-Mail           sales@algas-sdi.com  
WebSite         www.algas-sdi.com

## **Your Distributor**